

LAB MANUAL

Lab Name : MD-II Lab
Lab Code : 6ME4-23
Branch : Mechanical Engineering
Year : 3rd Year



Department of Mechanical Engineering
St. Wilfred's Institute of Engineering & Technology, Ajmer
(RTU, Kota)

SYLLYBUS

Class: Sem. B.Tech.	Evaluation
Branch-ME	Examination Time = 3:00Hours
Schedule per Week Practical Hrs.: 3:00	Maximum Marks = 75

S.No	Name of Experiments
1	Problems on Fatigue loading
2	Problems on Helical compression tension and tensional springs design
3	Problems on Curved beams
4	Problems on Preloaded bolts and bolts subjected to variable stresses
5	Problems on Belt, rope and chain drive system
6	Problems on Gear design
7	Problems on Sliding contact bearing design
8	Problems on Anti-friction bearing selection

Experiment No. 1

1. **Objective:** To Study Design Based on Fatigue Loads (Variable Loads).

2. **Theory:** Fatigue is a phenomenon associated with variable loading or more precisely to cyclic stressing or straining of a material. Fatigue loading (variable loading) is primarily the type of loading which causes cyclic variations in the applied stress or strain on a component. Thus any variable loading is basically a fatigue loading.

In reality most mechanical components experience variable loading due to Change in the magnitude of applied load, i.e. punching or shearing operations and Change in direction of load application, i.e. connecting rod.

3. **Nomenclature Used in Fatigue loading:**

s_m =Mean stress

s_a = Alternative stress

S_e = Endurance limit

S_{em} = Modified Endurance limit

S_y = Yield strength

S_u = Ultimate strength

Fos=Factor of safety

τ = Shear stress

4. **Design Based on Fatigue loading:**

There are three major design criteria given for fatigue design

1. Soderberg design criteria (Soderberg line)
2. Goodman design criteria (Goodman line)
3. Gerber design criteria (Gerber parabola)

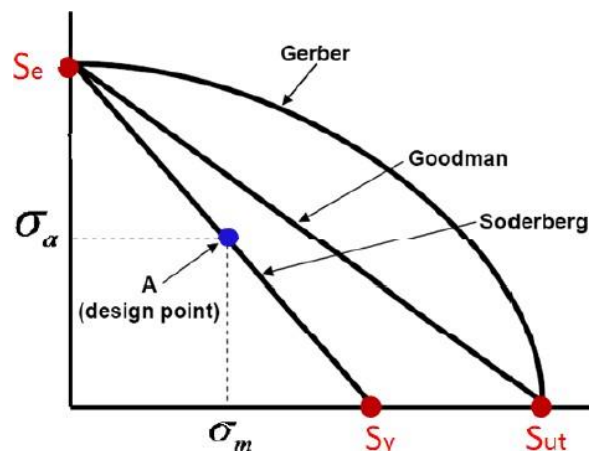

Figure 1.1-Design criteria based on fatigue

4.1. Soderberg Design Criteria (Soderberg Line):

$$\frac{\sigma_m}{S_y} + \frac{\sigma_a K_f}{S_{em}} = \frac{1}{fos} \quad (1.1)$$

4.2 Goodman Design Criteria (Goodman Line):

$$\frac{\sigma_m K_t}{S_{ul}} + \frac{\sigma_a K_f}{S_{em}} = \frac{1}{fos} \quad (1.2)$$

4.3 Gerber Design Criteria (Gerber Parabola):

$$\frac{\sigma_a}{\sigma_e} + fos \left(\frac{\sigma_m}{\sigma_{ul}} \right)^2 = \frac{1}{fos} \quad (1.3)$$

5. Design for Combined Loading

$$\sigma_m + \frac{\sigma_a K_f \sigma_{ul}}{\sigma_{em}} = \sigma_{eq} \quad (1.4)$$

6. Modified Endurance limit:

$$\sigma_{em} = K_{sur} \times K_{size} \times K_{load} \times K_{temp.} \times K_{misc.} \times \sigma_e \quad (1.5)$$

7. Fatigue Stress Concentration Factor

$$K_f = 1 + q(K_t - 1) \quad (1.6)$$

8. Sample Problems:

Q.1 A cantilever beam made of cold drawn carbon steel of circular cross-section as shown in Figure, is subjected to a load which varies from $-F$ to $3F$. Determine the maximum load that this member can withstand for an indefinite life using a factor of safety as 2. The theoretical stress concentration factor is 1.42 and the notch sensitivity is 0.9. Assume the following values:

- Ultimate stress = 550 MPa
- Yield stress = 470 MPa
- Endurance limit = 275 MPa
- Size factor = 0.85
- Surface finish factor = 0.89

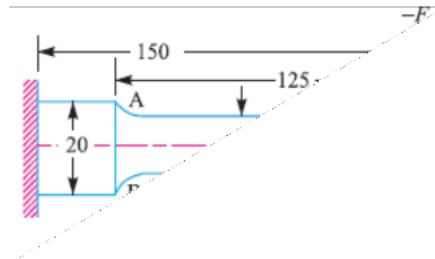

Q.2 A centrifugal blower rotates at 600 r.p.m. A belt drive is used to connect the blower to a 15 kW and 1750 r.p.m. electric motor. The belt forces a torque of 250 N-m and a force of 2500 N on the shaft. Fig. 6.20 shows the location of bearings, the steps in the shaft and the plane in which the resultant belt force and torque act. The ratio of the journal diameter to the overhung shaft diameter is 1.2 and the radius of the fillet is 1/10th of overhung shaft diameter. Find the shaft diameter, journal diameter and radius of fillet to have a factor of safety 3. The blower shaft is to be machined from hot rolled steel having the following values of stresses:

- Endurance limit = 180 MPa; Yield point stress = 300 MPa; Ultimate tensile stress = 450 MPa

Experiment No. 2

- Objective:** To Study Design of Helical Spring.
- Function/Application:** Springs are used in machine members to providing Cushioning, absorbing, or controlling of energy due to shock and vibration (car or railway buffers), Control the motion (cam and its follower, brakes, clutches, governors) ,Measuring the force (Spring balances, gages) and Store of energy (clocks or starters).
- Types of spring:** Helical, leaf, spiral springs are the common types of spring used in mechanical systems.
- Helical Spring:**

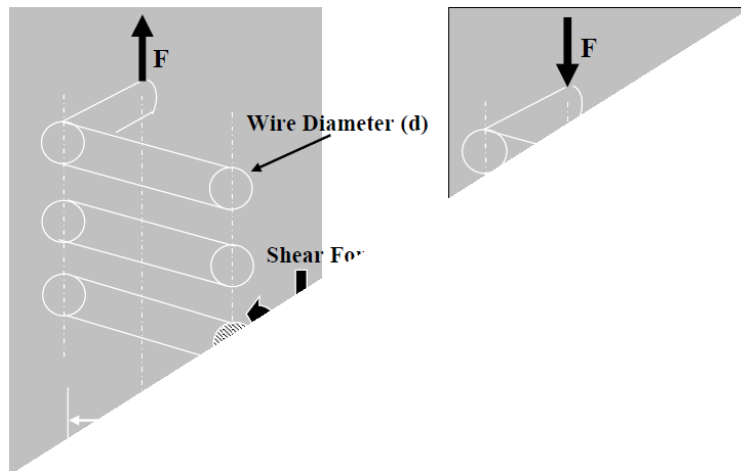
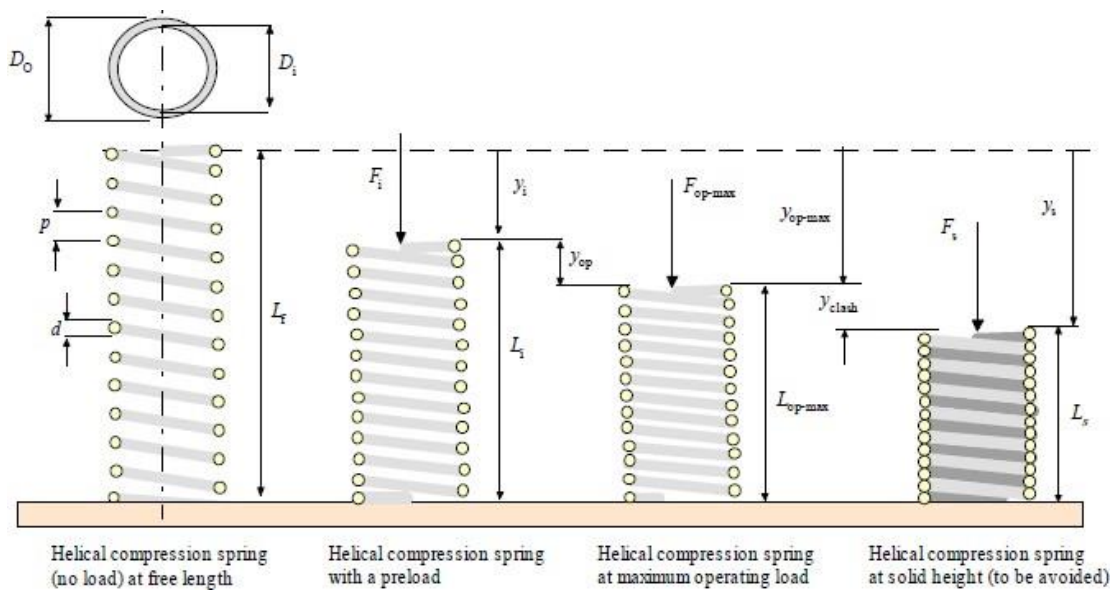

Figure 2.1-Helical Spring

5. Nomenclature Used in Helical spring:

d =	Wire diameter	τ_a =	Alternativeshear stress
D =	Mean diameter of spring	τ_m =	Mean shear stress
F =	External load acting at center of the spring	τ_e =	Endurance limit
L =	Spring length under preload	f_{os} =	Factor of safety
L_s =	Solid spring length	K =	Spring rate
K_s =	Shear stress correction factor	W_s =	Weight of spring
K_w =	Wahl correction factor	f =	Surge frequency
C =	Spring constant		
N =	Number of active turns		
G =	Modulus of rigidity		
δ =	Deflection of Spring		
y_i =	Spring deflection under preload		
Y_s =	Solid spring displacement under force F_s		
Y_{op-max} =	maximum operating deflection under maximum operating force		
Y_{clash} =	Difference between Y_s and Y_{op-max}		



6. Stresses in Helical Spring:

The shear stress in the spring wire due to torsion is

Figure 2.2- Nomenclature of helical spring

$$\tau_r = \frac{8FD}{\pi d^3} \quad (2.1)$$

Average shear stress in the spring wire due to force F is

$$\tau_f = \frac{4F}{\pi d^3} \quad (2.2)$$

Maximum shear stress the spring wire is

$$\tau_{\max} = \tau_r + \tau_f \quad (2.3)$$

$$\tau_{\max} = K_s \frac{8FD}{\pi d^3} \quad (2.4)$$

Where $K_s = 1 + \frac{1}{2C}$ and $C = \frac{D}{d}$

To take care of the curvature effect, the earlier equation for maximum shear stress in the spring wire is modified as

$$\tau_{\max} = K_w \frac{8FD}{\pi d^3} \quad (2.5)$$

Where K_w is Wahl correction factor, which takes care of both curvature effect and shear stress correction factor and is expressed as,

$$K_w = \frac{4C-1}{4C+1} + \frac{0.615}{C} \quad (2.6)$$

7. Deflection in Helical Spring:

Deflection of helical spring is given by the formula

$$\delta = \frac{8FND^3}{Gd^4} \quad (2.7)$$

8. Spring under variable loading:

Soderberg failure criterion for springs is

$$\frac{1}{FOS} = \frac{K_S \tau_m}{\tau_y} + \frac{K_W \tau_a}{\tau_y} \left(\frac{2\tau_y}{\tau_e} - 1 \right) \quad (2.8)$$

9. Buckling of spring:

$$L < \frac{\pi D}{C_e} \sqrt{\frac{2(E-G)}{2G+E}} \quad (2.9)$$

$$L < 2.57 \frac{D}{C_e}, \text{ for steel} \quad (2.10)$$

Where C_e is the end condition constant.

10. Spring Surge (Critical frequency)

Both ends within flat plates

$$f = \frac{1}{2} \sqrt{\frac{Kg}{W_s}} \quad (2.11)$$

One end free and other end on flat plate

$$f = \frac{1}{4} \sqrt{\frac{Kg}{W_s}} \quad (2.12)$$

11. Sample Problems:

Q.1A concentric spring for an aircraft engine valve is to exert a maximum force of 5000 N under an axial deflection of 40 mm. Both the springs have same free length, same solid length and are subjected to equal maximum shear stress of 850 MPa. If the spring index for both the springs is 6, find (a) the load shared by each spring, (b) the main dimensions of both the springs, and (c) the number of active coils in each spring. Assume $G = 80 \text{ kN/mm}^2$ and diametral clearance to be equal to the difference between the wire diameters.

Q.2Composite spring has two closed coil helical springs as shown in Fig. 23.22 (b). The outer spring is 15 mm larger than the inner spring. The outer spring has 10 coils of mean diameter 40 mm and wire diameter 5mm. The inner spring has 8 coils of mean diameter 30 mm and wire diameter 4 mm. When the spring is subjected to an axial load of 400 N, find 1. Compression of each spring, 2. load shared by each spring, and 3. Shear stress induced in each spring. The modulus of rigidity may be taken as 84 kN/mm^2 .

Experiment No. 3

- Objective:** To Study Curved Beam.
- Function/Application:** Curved beams are the parts of machine members found in C-clamps, crane hooks, frames, of presses, riveters, punches, shears, boring machines, planers etc.
- Shape of Curved Beam:** I and H sections are most common sections used for Curved beam.
- Difference Between Curved Beam and Straight Beam:** In straight beams the neutral axis of the section coincides with its centroidal axis and the stress distribution in the beam is linear. But in the case of curved beams the neutral axis is shifted towards the centre of curvature of the beam causing a nonlinear [hyperbolic] distribution of stress. The neutral axis lies between the centroidal axis and the centre of curvature and will always be present within the curved beams.

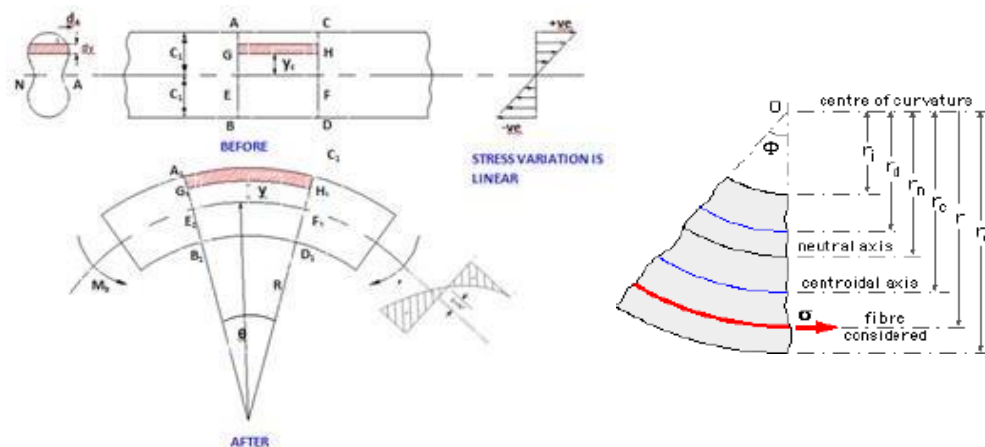

Figure 3.1-Curved Beam

5. Nomenclature Used in Curved Beam:

- C_i = Distance from neutral axis to inner radius of curved beam
- C_o = Distance from neutral axis to outer radius of curved beam
- C_1 = Distance from centroidal axis to inner radius of curved beam
- C_2 = Distance from centroidal axis to outer radius of curved beam
- F = Applied load or Force
- A = Area of cross section
- L = Distance from force to centroidal axis at critical section
- d = Direct stress
- σ_{bi} = Bending stress at the inner fiber
- M_b = Applied Bending Moment
- r_i = Inner radius of curved beam
- r_o = Outer radius of curved beam

$r_c =$ Radius of centroidal axis
 $r_n =$ Radius of neutral axis

6. Stresses in Curved Beam:

General equation for the stress in a fiber at a distance 'y' from neutral axis is given:

$$\sigma_b = \frac{M_b Y}{(y + r_n) A e} \quad (3.1)$$

At the outer fiber, $y = C_o$

$$\sigma_b = \frac{M_b C_o}{R_o A e} \quad (3.2)$$

At the inner fiber, $y = C_i$

$$\sigma_b = \frac{M_b C_i}{R_i A e} \quad (3.3)$$

7. Location of Neutral axis:

7.1 By considering a rectangular cross-section:

$$R_n = \frac{h}{\log \frac{R_o}{R_i}} \quad (3.4)$$

7.2 By considering a circular cross-section:

$$R_n = \frac{(\sqrt{R_i} + \sqrt{R_o})^2}{4} \quad (3.5)$$

8. Eccentricity:

$$e = R - R_n \quad (3.6)$$

9. Total stress

If direct Tensile/compressive stress considered

$$\sigma_t = \sigma_t + \sigma_d \quad (3.7)$$

10. Sample Problems:

Q.1 The figure shows a loaded offset bar. What is the maximum offset distance 'x' if the allowable stress in tension is limited to 50N/mm^2 .

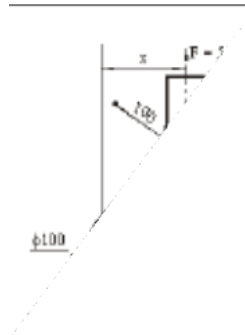

Q.2 Compute the combined stress at the inner and outer fibers in the critical cross section of a crane hook is required to lift loads up to 25kN . The hook has trapezoidal cross section with parallel sides 60mm and 30mm , the distance between them being 90mm . The inner radius of the hook is 100mm . The load line is nearer to the surface of the hook by 25mm the centre of curvature at the critical section. What will be the stress at inner and outer fiber, if the beam is treated as straight beam for the given load?

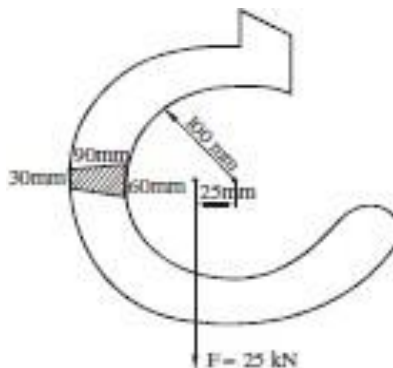

Experiment No. 4

- Objective:** To Study Design Flexible Machine Elements (Flat Belt Drive).
- Function/Application:** Belt drives are called flexible machine elements. Flexible machine elements are used for a large number of industrial applications. Belt are used in conveying system in transportation of coal, minerals etc. over a long distance. It is also used for power transmission system mainly used for running of various industrial appliances using prime movers like electric motors, I.C. Engine etc. Belt drive is strong replacement of rigid type power transmission system.
- Types of Belt:** Flat belt and V belt drive are the common types of belt used in mechanical systems.
- Flat Belt Drive:**

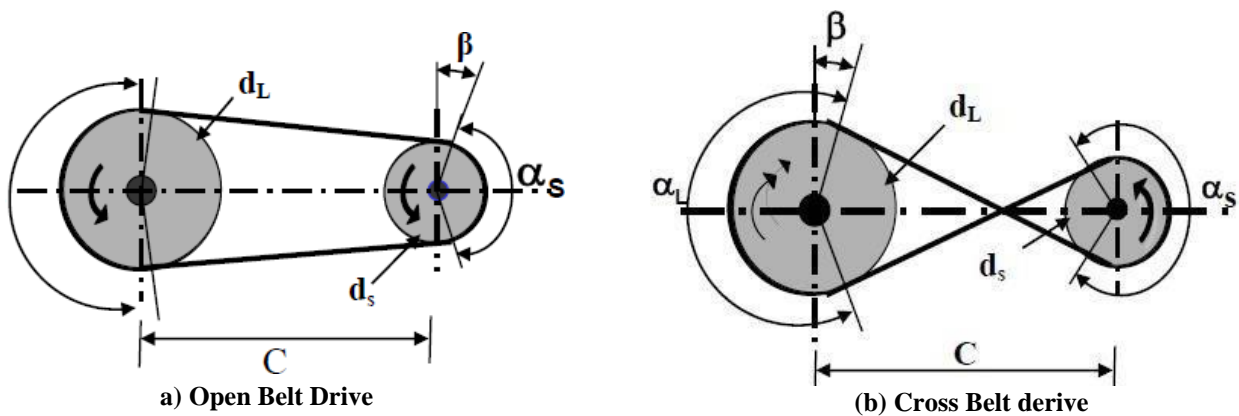

Figure 4.1-Arrangements of Belt Drive

5. Nomenclature Used in Belt Drive:

d_L =	Diameter of the larger pulley
d_s =	Diameter of the smaller pulley
α_L =	Angle of wrap of the larger pulley
α_s =	Angle of wrap of the smaller pulley
C =	Center distance between the two pulleys
L_0 =	Length of open belt
L_c =	Length of Cross belt
V =	Peripheral velocity of the pulley
M =	Mass of the belt of unit length
N_L =	Rotational speeds of the large pulley
N_s =	Rotational speeds of the small pulley
t =	Belt thickness
S =	Slip

T_i = Initial Tension in belt
 T_1 = Tension in belt at tight side
 T_2 = Tension in belt at slack side

6. Length Belt Derive:

Length of Open Belt:

$$L_0 = \frac{\pi}{2}(d_L + d_s) + 2C + \frac{1}{2C}(d_L - d_s)^2 \quad (4.1)$$

Length of Cross Belt:

$$L_c = \frac{\pi}{2}(d_L + d_s) + 2C + \frac{1}{2C}(d_L + d_s)^2 \quad (4.2)$$

7. Angle of Wrap:

Angle of wrap for Open Belt

$$\alpha_L = 180^\circ + 2\beta \quad (4.3)$$

$$\alpha_s = 180^\circ - 2\beta \quad (4.4)$$

Angle of wrap for Cross Belt

$$\alpha_L = \alpha_s = 180^\circ + 2\beta \quad (4.5)$$

Where angle β is,

$$\beta = \frac{1}{2C}(d_L - d_s) \quad (4.6)$$

8. Relationship Between Belt Tensions:

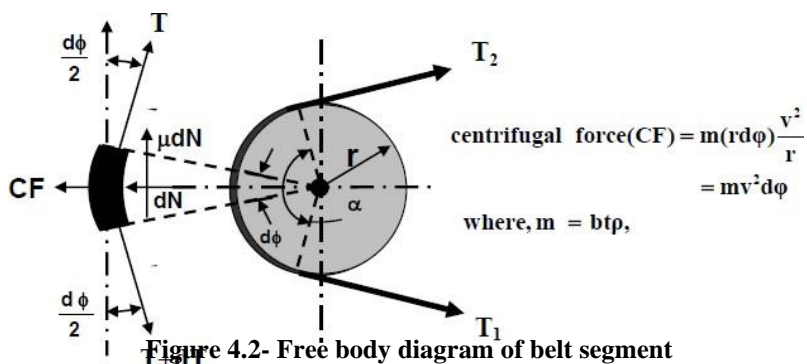

Figure 4.2- Free body diagram of belt segment

Relationship between belt tensions

$$\frac{T_1 - Mv^2}{T_2 - Mv^2} = e^{\mu\alpha} \quad (4.7)$$

If Centrifugal force is not considered

$$\frac{T_1}{T_2} = e^{\mu\alpha} \quad (4.8)$$

9. Velocity Ratio of Belt Drive:

Velocity ratio of belt drive is defined as,

$$\frac{N_L}{N_s} = \frac{d_s + t}{d_l + t} (1 - S) \quad (4.9)$$

10. Power Transmission of Belt Drive:

Power transmission of a belt drive is expressed as,

$$P = (T_1 - T_2)V \quad (4.10)$$

11. Initial Tension in Belt:

If belt length remains the same, i.e., the elongation is same as the contraction,

(a) Without centrifugal force:

$$T_i = \frac{T_1 + T_2}{2} \quad (4.11)$$

(b) With centrifugal force:

$$T_i = \frac{T_1 + T_2 + 2T_c}{2} \quad (4.12)$$

12. Stress in Belt Due to Centrifugal Force:

$$s_c = \rho \frac{v^2}{10^6 g} \quad (4.13)$$

13. Sample Problems:

Q.1 Design a flat belt drive to transmit 35kW, from an electric motor running at 900 rpm to centrifugal pump at approximately 300 rpm.

Q.2 An electric motor drives an exhaust fan. Following data are provided

	Motor pulley	Fan pulley
Diameter	400 mm	1600 mm
Angle of warp	2.5 radians	3.78 radians
Coefficient of friction	0.3	0.25
Speed	700 r.p.m.	-
Power transmitted	22.5 kW	-

Calculate the width of 5 mm thick flat belt. Take permissible stress for the belt material as 2.3 MPa.

Experiment No. 5

- Objective:** To Study Design Flexible Machine Elements (V Belt Drive).
- Function/Application:** Among flexible machine elements, perhaps V-belt drives have widest industrial application. These belts have trapezoidal cross section and do not have any joints. Therefore, these belts are manufactured only for certain standard lengths. To accommodate these belts the pulleys have V shaped grooves which makes them relatively costlier. Multiple groove pulleys are available to accommodate number of belts, when large power transmission is required. V-belt drives are most recommended for shorter center distances. In comparison to flat belt drives, these drives are slightly less efficient. V belt can have transmission ratio up to 1:15 and belt slip is very small. As the belts are endless type, V-belt drives do not suffer from any joint failure and are quiet in operation. V-belts constitute fabric and cords of cotton, nylon etc. and impregnated with rubber.
- Standard Section of V-Belt:** The standard V-belt sections are A, B, C, D and E. The design data book contains design parameters for all the sections of V-belt.
- Designation of V Belt:** V-belts are designated with nominal inside length. The inside length is given as,

$$\text{Inside length} + X = \text{Pitch Length} \quad (5.1)$$

Table 5.1

Value of X				
Belt Section	A	B	C	D
X(mm)	36	43	56	79

For example, a B- section belt with nominal inside length of 1016 mm or 40 inches (nearest value obtained from belt catalogue) is required for a V-belt drive. Then this belt is designated as

B 1016/40

Nomenclature Used in Belt Drive:

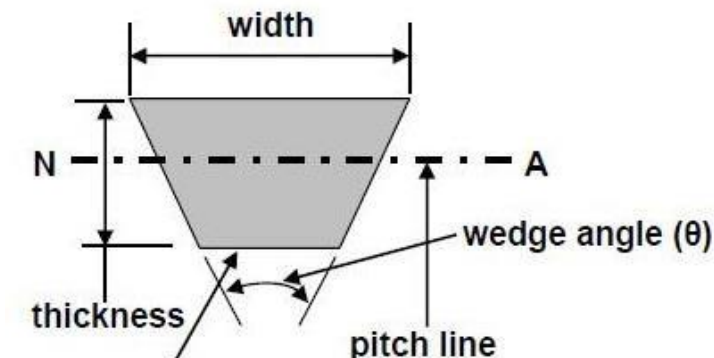

Figure 5.1-Nomenclature of V-Belt

6. Center distance of Pulleys:

$$\text{Minimum center distance } (C_{\min}) = 0.55(d_L + d_s) + T \quad (5.2)$$

$$\text{Maximum center distance } (C_{\max}) = 2(d_L + d_s) \quad (5.3)$$

7. Transmitting Capacity:

Power transmitting capacity in S.I. units is given as,

$$P(\text{KW}) = \frac{\pi a v}{1000} \left[s_d - \rho \frac{v^2}{10^6 g} \right] \left[\frac{e^{\mu \alpha} - 1}{e^{\mu \alpha}} \right] \quad (5.4)$$

8. Number of belts:

Number of belts are given as,

$$N = \frac{P F_a}{\text{KW} F_d F_c} \quad (5.5)$$

where

F_a = Correction Factor according to service

F_d = Correction Factor for arc of contact

F_c = Correction Factor for length

9. Sample Problems:

Q1 A V-belt is driven on a flat pulley and a V-pulley. The drive transmits 20 kW from a 250 mm diameter V-pulley operating at 1800 r.p.m. to a 900 mm diameter flat pulley. The centre distance is 1 m, the angle of groove 40° and $\mu = 0.2$. If density of belting is 1110 kg / m^3 and allowable stress is 2.1 MPa for belt material, what will be the number of belts required if C-size V-belts having 230 mm^2 cross-sectional area are used.

Q2 A rope drive is to transmit 250 kW from a pulley of 1.2 m diameter, running at a speed of 300 r.p.m. The angle of lap may be taken as π radians. The groove half angle is 22.5° . The ropes to be used are 50 mm in diameter. The mass of the rope is 1.3 kg per metre length and each rope has a maximum pull of 2.2 kN, the coefficient of friction between rope and pulley is 0.3. Determine the number of ropes required. If the overhang of the pulley is 0.5 m, suggest suitable size for the pulley shaft if it is made of steel with a shear stress of 40 MPa.

Experiment No. 6

- Objective:** To Study Design of Sliding Contact Bearing.
- Function/Application:** A bearing is a machine element which supports another moving machine element (known as journal). It permits a relative motion between the contact surfaces of the members, while carrying the load. A little consideration will show that due to the relative motion between the contact surfaces, a certain amount of power is wasted in overcoming frictional resistance and if the rubbing surfaces are in direct contact, there will be rapid wear. In order to reduce frictional resistance and wear and in some cases to carry away the heat generated, a layer of fluid (known as lubricant) may be provided. The lubricant used to separate the journal and bearing is usually a mineral oil refined from petroleum, but vegetable oils, silicon oils, greases etc., may be used.
- Types of Sliding contact bearings:** Full journal bearing, Partial journal bearing, Fitted journal bearing. Are the common types of Sliding contact bearings.

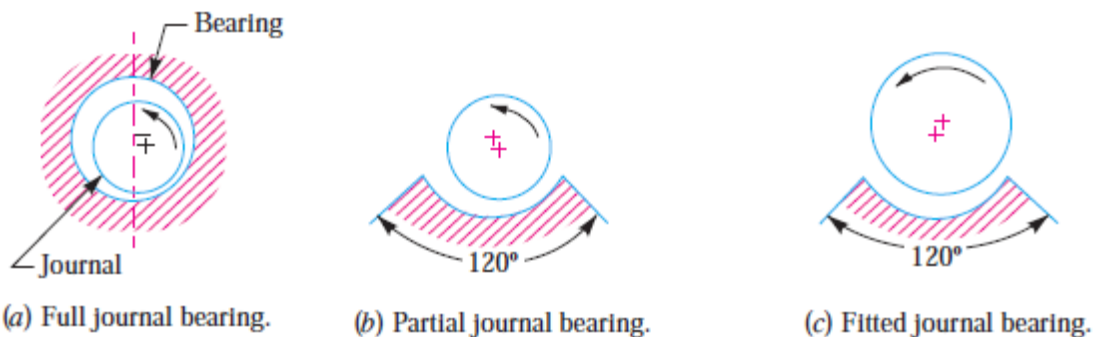

4. Nomenclature Used Sliding contact bearings:

μ =	Coefficient of friction,
Z =	Absolute viscosity of the lubricant, in kg / m-s,
N =	Speed of the journal in r.p.m.,
p =	Bearing pressure on the projected bearing area in N/mm ² ,
=	Load on the journal / $l \times d$
d =	Diameter of the journal,
l =	Length of the bearing, and
c =	Diametric clearance
Zn/p =	Bearing characteristic number
k =	Factor to correct for end leakage
w =	Load on bearing in N
V =	Rubbing Velocity
C =	Heat dissipation coefficient in W/m ² /°C,
A =	Projected area of the bearing in m ² = $l \times d$,
t_b =	Temperature of the bearing surface in °C,
t_a =	Temperature of the surrounding air in °C.

5. Coefficient of Friction:

In order to determine the coefficient of friction for well lubricated full journal bearings, the following empirical relation established by McKee based on the experimental data, may be used.

$$\mu = \frac{33}{10^8} \left(\frac{ZN}{p} \right) \left(\frac{d}{c} \right) + k \quad (6.1)$$

6. Somerfield Number:

The Somerfield number is also a dimensionless parameter used extensively in the design of journal bearings. Mathematically,

$$\text{Somerfield number} = \left(\frac{ZN}{p} \right) \left(\frac{d}{c} \right)^2 \quad (6.2)$$

7. Heat Generated in a Journal Bearing:

The heat generated in a bearing is due to the fluid friction and friction of the parts having relative motion. Mathematically, heat generated in a bearing,

$$Q_g = \mu \cdot W \cdot V \text{ N-m/s} \quad (6.3)$$

Where

$$W = \text{Pressure on the bearing in N/mm}^2 \times \text{Projected area of the bearing in mm}^2 = p (l \times d) \quad (6.4)$$

$$V = \frac{\pi d N}{60} \quad (6.5)$$

8. Heat Dissipated in a Journal Bearing:

$$Q_d = C.A.(t_b - t_a) \text{ J/s or W} \quad (6.6)$$

Temperature of the bearing (t_b) is approximately mid-way between the temperature of the oil film (t_0) and the temperature of the outside air (t_a).

$$(t_b - t_a) = \frac{1}{2} (t_0 - t_a)$$

9. Amount of artificial cooling:

$$Q = Q_g - Q_d \quad (6.7)$$

10. Mass of lubricating oil required for artificial cooling:

$$Q_t = m.S.t \quad (6.8)$$

11. Design Procedure for Journal Bearing:

St. Wilfred's Institute of Engineering & Technology, Ajmer

The following procedure may be adopted in designing journal bearings, when the bearing load, the diameter and the speed of the shaft are known

1. Determine the bearing length by choosing a ratio of l / d from Table 'Design values for journal bearings'.
2. Check the bearing pressure, $p = \frac{W}{ld}$ from Table 'Design values for journal bearings'.
3. Assume a lubricant from Table 'Absolute viscosity of commonly used lubricating oils' and its operating temperature (t_0). This temperature should be between 26.5°C and 60°C with 82°C as a maximum for high temperature installations such as steam turbines.
4. Determine the operating value of ZN / p for the assumed bearing temperature and check this value with corresponding values in Table 'Design values for journal bearings', to determine the possibility of maintaining fluid film operation.
5. Assume a clearance ratio c / d from Table 'Design values for journal bearings'.
6. Determine the coefficient of friction (μ) by using the relation as discussed in 6.1.
7. Determine the heat generated by using the relation as discussed in 6.3.
8. Determine the heat dissipated by using the relation as discussed in 6.6.
9. Determine the thermal equilibrium to see that the heat dissipated becomes at least equal to the heat generated. In case the heat generated is more than the heat dissipated then either the bearing is redesigned or it is artificially cooled by water.

12. Sample Problems:

Q.1 In a journal bearing application an oil of kinematic viscosity at 100°C corresponding to 46 seconds as found from Saybolt viscometer is used. Determine its absolute viscosity and corresponding oil in SAE and ISO VG grades.

Q.2A footstep bearing supports a shaft of 150 mm diameter which is counter bored at the end with a hole diameter of 50 mm. If the bearing pressure is limited to 0.8 N/mm^2 and the speed is 100 r.p.m.; find : 1. The load to be supported; 2. The power lost in friction; and 3. The heat generated at the bearing.

Assume coefficient of friction = 0.015.

Experiment No. 7

- Objective:** To Study Design of Anti-frictional Bearing.
- Function/Application:** Rolling contact bearings are also called anti-friction bearing due to its low friction characteristics. These bearings are used for radial load, thrust load and combination of thrust and radial load. These bearings are extensively used due to its relatively lower price, being almost maintenance free and for its operational ease. However, friction increases at high speeds for rolling contact bearings and it may be noisy while running.
- Types of Anti-frictional Bearing:** Ball bearing and roller bearing are the common types of Anti-frictional Bearing.

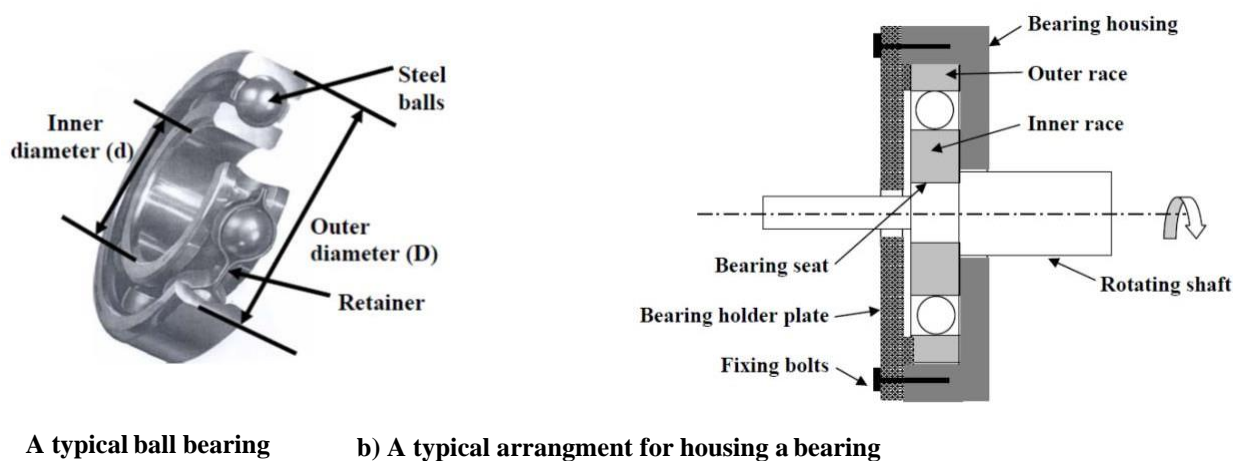

a) A typical ball bearing b) A typical arrangement for housing a bearing

Figure 7.1-Anti-frictional bearing

4. Nomenclature Used Anti-frictional Bearings:

$p =$	Bearing pressure on the projected bearing area in N/mm^2 ,
$=$	Load on the journal / $l \times d$
$L =$	life in millions of revolution or life in hours
$C =$	Basic or dynamic load rating
$P_e =$	Equivalent radial load
$P_r =$	Given radial load
$P_a =$	Given axial load
$V =$	Rotation factor (1.0, inner race rotating; 1.2, outer race rotating)
$X :$	A radial factor
$Y :$	An axial factor

5. Bearing Load:

If two groups of identical bearings are tested under loads P_1 and P_2 for respective lives of L_1 and L_2 , then

$$\frac{L_1}{L_2} = \left(\frac{P_2}{P_1}\right)^a \tag{7.1}$$

Where

a - constant which is 3 for ball bearings and 10/3 for roller bearings

6. Basic Load Rating:

It is that load which a group of apparently identical bearings can withstand for a rating life of onemillion revolutions.

$$C = P(L)^{1/4} \tag{7.2}$$

Where, C is the basic or dynamic load rating

7. Equivalent Radial Load:

If a bearing is subjected to both axial and radial load, then an equivalent radial load is estimated as,

$$P_e = PV_r \tag{7.3}$$

$$P_e = XPV_r + YV_a$$

8 Sample Problem:

Q.1A simply supported shaft, diameter 50mm, on bearing supports carries a load of 10kN at its center. The axial load on the bearings is 3kN. The shaft speed is 1440 rpm. Select a bearing for 1000 hours of operation.

Q.2Select a single row deep groove ball bearing with the operating cycle listed below, which will have a life of 15000 hours.

Fraction of cycle	Type of load	Radial (N)	Thrust (N)	Speed (rpm)	Service factor
1/10	Heavy shocks	2000	1200	400	3.0
1/10	Light shocks	1500	1000	500	1.5
1/5	Moderate shocks	1000	1500	600	2.0
3/5	No shocks	1200	2000	800	1.0

Experiment No. 8

1. **Objective:** To Study Design of Spur Gear.
2. **Function/Application:** Spur gears have high power transmission efficiency, constant velocity ratio, and they are compact and easy to install. Spur gear offers no slip and can be used to transmit large amount of power. Therefore spur gears have wide range of application like:
 - Metal cutting machines
 - Power plants
 - Marine engines
 - Mechanical clocks and watches
 - Fuel pumps
 - Washing Machines
 - Gear motors and gear pumps
 - Rack and pinion mechanisms
 - Material handling equipments
 - Automobile gear boxes
 - Steel mills
 - Rolling mills

3. **Terminology Used in Gear:** The following Terms (shown in figure 8.1) are frequently used in design of gears.

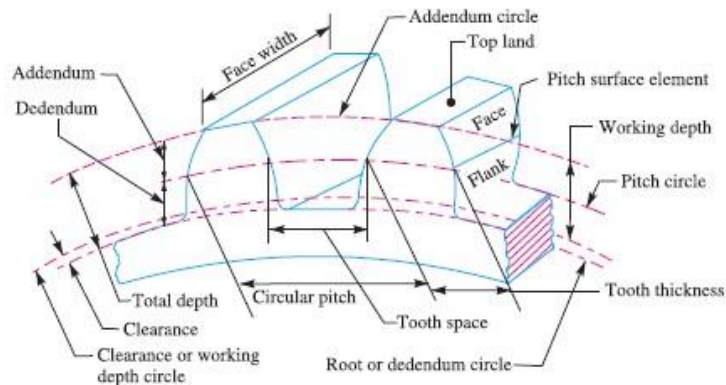

Figure 8.1- Terminology in gears

4. **Nomenclature Used Gears:**

D= Diameter of pitch circle

T= No of teeth on the wheel

P_c = Circular pitch

P_d = Diametral pitch

m= module

W_T = Tangential load acting on gear tooth

H= Length of the tooth

v= pitch line velocity

W_D = Total dynamic load

W_I = Increment load due to dynamic action

b= Face width of gears

E_P = Young's modulus for the material of the pinion in N/mm².

E_G = Young's modulus for the material of gear in N/mm².

e = Tooth error action in mm.

W_w = Maximum or limiting load for wear

Q=Ratio factor

K=Load- stress factor

A= Pressure angle

s_{es} = Surface endurance limit

5. **Tangential Load Acting on Gear Tooth:**

Wilfred Lewis investigated for strength of gear teeth. He derived an equation which is now extensively used by industry in determining the size and proportions of the gears.

$$W_T = \sigma_w \times b \times P_c \times y \quad (8.1)$$

Where, y= is known as Lewis factor or tooth form factor

$$y = 0.124 - \frac{0.684}{T}, \text{ for } 14\frac{1}{2}^0 \text{ composite and full depth} \quad (8.2)$$

$$y = 0.154 - \frac{0.912}{T}, \text{ for } 20^{\circ}\text{full depth} \quad (8.2)$$

6. Permissible Working Stress for Gear Teeth in the Lewis Equation:

$$\sigma_w = \sigma_a \times C_v \quad (8.3)$$

6.1 For ordinary cut gears operating at velocities upto 12.5 m/s.

$$C_v = \frac{3}{3+v} \quad (8.4)$$

6.2 For carefully cut gears operating at velocities upto 12.5 m/s.

$$C_v = \frac{4.5}{4.5+v} \quad (8.5)$$

6.3 For very accurately cut and metallic gears operating at velocities upto 20 m/s

$$C_v = \frac{6}{6+v} \quad (8.5)$$

6.4 For precision gear cut with high accuracy and operating at velocities upto 20 m/s

$$C_v = \frac{0.75}{0.756 + \sqrt{v}} \quad (8.6)$$

7. Dynamic Tooth Load:

The dynamic loads are due to the following reasons:

1. Inaccuracies of tooth spacing,
2. Irregularities in tooth profiles, and
3. Deflections of teeth under load.

A closer approximation to the actual conditions may be made by the use of equations based on extensive series of tests, as follows

$$W_D = W_T + W_I \quad (8.7)$$

7.1 Increment load due to dynamic action

$$W_I = \frac{21v(b.C + W_T)}{21v + \sqrt{b.C + W_T}} \quad (8.8)$$

Where, the value of C in N/mm be determined by using the following relation

$$C = \frac{K.s}{\frac{1}{E_p} + \frac{1}{E_G}} \quad (8.9)$$

The factor depending upon the form of teeth.

8. Static Tooth Load:

The static tooth load (also called beam strength or endurance strength of the tooth) is obtained by Lewis formula by substituting flexural endurance limit or elastic limit stress (σ_e) in place of permissible working stress

$$W_T = \sigma_e \times b \times P_c \times y \quad (8.10)$$

9. Wear Tooth Load:

The maximum or the limiting load for satisfactory wear of gear teeth, is obtained by using the following Buckingham equation

$$W_w = D_p \times b \times Q \times K \quad (8.11)$$

Where, Q is ratio factor is given by

$$Q = \frac{2 \times VR}{VR + 1}, \text{ for External gears} \quad (8.12)$$

$$Q = \frac{2 \times VR}{VR - 1}, \text{ for Internal gears} \quad (8.13)$$

10. Load-Stress Factor:

According to Buckingham, the load stress factor is given by the following relation:

$$K = \frac{\sin(\alpha) \sigma_{ES}^2}{1.4} \left(\frac{1}{E_p} + \frac{1}{E_G} \right) \quad (8.14)$$

11. Design Procedure for Spur Gears:

11.1 In order to design spur gears, the following procedure may be followed:

1. First of all, the design tangential tooth load is obtained from the power transmitted and the pitch line velocity by using the following relation

$$W_T = \frac{P}{v} C_s \quad (8.15)$$

Where, P is Power transmitted and C_s = Service factor

2. Apply the Lewis equation as (art. 8.1)

- The Lewis equation is applied only to the weaker of the two wheels (i.e. pinion or gear).
 - When both the pinion and the gear are made of the same material, then pinion is the weaker.
 - When the pinion and the gear are made of different materials, then the product of $(\sigma_w \times y)$ or $(\sigma_a \times y)$ is the deciding factor. The Lewis equation is used to that wheel for which $(\sigma_w \times y)$ or $(\sigma_a \times y)$ is less.
 - Product of $(\sigma_w \times y)$ is called strength factor of the gear.
3. Calculate the dynamic load on the tooth by using Buckingham equation (Art. 8.8)
 4. Find the static tooth load using art 8.10
 5. Find the wear tooth load by using art. 8.11

11.2 Design of Shaft for Spur Gears:

➤ First of all, find the normal load (W_N), acting between the tooth surfaces. It is given by

$$W_N = W_T / \cos(\alpha) \quad (8.16)$$

➤ The weight of the gear is given by

$$W_G = 0.0018 T_G \cdot b \cdot m^2 \text{ (in N)} \quad (8.17)$$

➤ Now the resultant load acting on the gear

$$W_R = \sqrt{2W_N \times W_G \cos(\alpha) + W_G^2 + W_N^2} \quad (8.18)$$

➤ If the gear is overhung on the shaft, then bending moment on the shaft due to the resultant load

$$M = W_R \times x \quad (8.19)$$

Where x = overhang

➤ Since the shaft is under the combined effect of torsion and bending, therefore we shall determine the equivalent torque. We know that equivalent torque,

$$T_e = \sqrt{M^2 + T^2} \quad (8.20)$$

➤ The diameter of the gear shaft (d) is determined by using the following relation

$$T_e = \frac{\pi \tau d^3}{16} \quad (8.21)$$

❖ Proceeding in the similar way as discussed above, we may calculate the diameter of the pinion shaft.

11.3 Design of Arms for Spur Gears:

11.3.1 Stalling load:

The stalling load may be taken as the design tangential load divided by the velocity factor

$$W_s = \frac{W_T}{C_v} \quad (8.22)$$

11.3.2 Bending Moment on Each arm:

$$M = \frac{W_s \times D}{2n} \quad (8.23)$$

12 Sample problems:

Q.1 A reciprocating compressor is to be connected to an electric motor with the help of spur gears. The distance between the shafts is to be 500 mm. The speed of the electric motor is 900 r.p.m. and the speed of the compressor shaft is desired to be 200 r.p.m. The torque, to be transmitted is 5000 N-m. Taking starting torque as 25% more than the normal torque, determine: 1. Module and face width of the gears using 20 degrees stub teeth, and 2. Number of teeth and pitch circle diameter of each gear. Assume suitable values of velocity factor and Lewis factor.

Q.2 motor shaft rotating at 1500 r.p.m. has to transmit 15 kW to a low speed shaft with a speed reduction of 3:1. The teeth are $14\frac{1}{2}$ involutes with 25 teeth on the pinion. Both the pinion and gear are made of steel with a maximum safe stress of 200 MPa. A safe stress of 40 MPa may be taken for the shaft on which the gear is mounted and for the key.

Design a spur gear drive to suit the above conditions. Also sketch the spur gear drive. Assume starting torque to be 25% higher than the running torque.

Experiment No. 9

- Objective:** To Study Design of Helical Gear.
- Function/Application:** These are highly used in transmission because they are quieter even at higher speed and are durable. The other possible applications of helical gears are in textile industry, blowers, feeders, rubber and plastic industry, sugar industry, rolling mills, food industry, elevators, conveyors, cutters, clay working machinery, compressors and in oil industry.
- Types of Helical Gears:** Single helical and double helical are the most common types of helical gears.
- Nomenclature Used Gears:**
*Same as spur gears discussed in experiment 8.

5. Tangential Load Acting on Gear Tooth:

Wilfred Lewis investigated for strength of gear teeth. He derived an equation which is now extensively used by industry in determining the size and proportions of the gears.

$$W_T = \sigma_w \times b \times P_c \times y \quad (9.1)$$

Where, y is known as Lewis factor or tooth form factor

$$y = 0.124 - \frac{0.684}{T}, \text{ for } 14\frac{1}{2} \text{ composite and full depth} \quad (9.2)$$

$$y = 0.154 - \frac{0.912}{T}, \text{ for } 20^\circ \text{ full depth} \quad (9.3)$$

6. Permissible Working Stress for Gear Teeth in the Lewis Equation:

$$\sigma_w = \sigma_a \times C_v \quad (9.4)$$

6.1 For peripheral velocities upto 5 m/s. to 10 m/s

$$C_v = \frac{6}{6+v} \quad (9.5)$$

6.2 For peripheral velocities upto 10 m/s. to 20 m/s

$$C_v = \frac{15}{15+v} \quad (9.6)$$

6.3 For peripheral velocities greater than 20m/s.

$$C_v = \frac{0.75}{0.756 + \sqrt{v}} \quad (9.7)$$

7. Dynamic Tooth Load:

The dynamic loads are due to the following reasons:

1. Inaccuracies of tooth spacing,
2. Irregularities in tooth profiles, and
3. Deflections of teeth under load.

A closer approximation to the actual conditions may be made by the use of equations based on extensive series of tests, as follows

$$W_D = W_T + \frac{21v(bC \cos^2 \alpha + W_T) \cos \alpha}{21v + \sqrt{bC \cos^2 \alpha + W_T}} \quad (9.8)$$

8. Static Tooth Load:

The static tooth load (also called beam strength or endurance strength of the tooth) is obtained by Lewis formula by substituting flexural endurance limit or elastic limit stress (σ_e) in place of permissible working stress

$$W_T = \sigma_e \times b \times P_c \times y \quad (9.9)$$

9. Wear Tooth Load:

The maximum or the limiting load for satisfactory wear of gear teeth, is obtained by using the following Buckingham equation

$$W_w = (D_p \times b \times Q \times K) / \cos^2 \alpha \quad (9.10)$$

Where, Q is ratio factor is given by

$$Q = \frac{2 \times VR}{VR + 1}, \text{ for External gears} \quad (9.11)$$

$$Q = \frac{2 \times VR}{VR - 1}, \text{ for Internal gears} \quad (9.12)$$

10. Load-Stress Factor:

According to Buckingham, the load stress factor is given by the following relation:

$$K = \frac{\sin(\alpha) \sigma_{ES}^2}{1.4} \left(\frac{1}{E_p} + \frac{1}{E_G} \right) \quad (9.13)$$

11. Design Procedure of Helical Gears:

*Design procedure of helical gears is same as spur gears discussed in experiment 8.

12. Sample Problems:

Q.1 Design a pair of helical gears for transmitting 22 kW. The speed of the driver gear is 1800 r.p.m. and that of driven gear is 600 r.p.m. The helix angle is 30° and profile is corresponding to 20° full depth system. The driver gear has 24 teeth. Both the gears are made of cast steel with allowable static stress as 50 MPa. Assume the face width parallel to axis as 4 times the circular pitch and the overhang for each gear as 150 mm. The allowable shear stress for the shaft material may be taken as 50 MPa. The form factor may be taken as $0.154 - 0.912 / TE$, where TE is the equivalent number of teeth. The velocity factor may be taken as $\frac{350}{350 + v}$, where v is pitch line velocity in m / min. The gears are required to be designed only against bending failure of the teeth under dynamic condition.

Q.2 A pair of helical gears are to transmit 15 kW. The teeth are 20° stub in diametral plane and have a helix angle of 45° . The pinion runs at 10 000 r.p.m. and has 80 mm pitch diameter. The gear has 320 mm pitch diameter. If the gears are made of cast steel having allowable static strength of 100 MPa; determine a suitable module and face width from static strength considerations and check the gears for wear, given $\sigma_{es} = 618$ MPa

Experiment No. 10

1. **Objective:** To Design a connecting rod.
2. **Function:** The main function of the connecting rod is to transmit the push and pull from the piston pin to crank pin. In many cases its secondary function is to convey the lubricating oil from the bottom end to the top end i.e. from the crank pin to the piston pin and then for splash of jet cooling of piston crown.
3. **Materials:** The materials for connecting rods range from mild or medium carbon steels to alloy steel. For high speed engines the connecting rods may also be made of duralumin and aluminum alloys
4. **Shape of Connecting Rod:** I and H sections are most common sections used for connecting rod

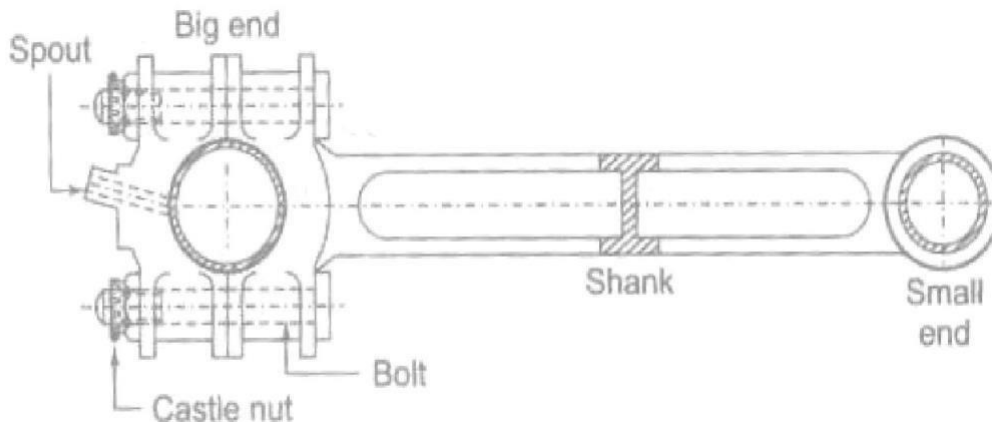

Figure 10.1 Connecting Rod

5. **Stresses in Connecting Rod:** The various forces acting on the on connecting rod are
 1. The combined effect of gas pressure on the piston and inertia of the reciprocating parts
 2. Friction of piston rings and that of piston.
 3. Inertia of connecting rod.
 4. The friction of two end bearings i.e. piston pin bearing and crank pin bearing.

6. Stress and Load Calculation:

6.1 Load Due To Gas Pressure and Piston Inertia

The load due to piston inertia = weight of reciprocating masses x acceleration

$$F_i = (Fw^2r (\cos\alpha + (r\cos^2\alpha)/l))/g \quad (10.1)$$

F= weight of reciprocating parts = weight of piston including that of rings+ weight of pistonpin + one third portion of connecting rod(small end portion)

W=Angular velocity of crank, rad/s

α = Crank angle from TDC

r= Crank radius, m

l= Rod length, m

6.2 Force Due To Friction of Piston Rings and That of Piston

$$P_f = h\pi D z p_r \mu \quad (10.2)$$

h = axial width of the rings

D = cylinder bore

z = no. of rings

p_r = pressure of rings,

μ = coefficient of friction, about 0.1

In the design calculation the effect of friction of piston rings and of the piston can be.

Inertia of connecting rod: the inertia of connecting rod will have two components: along the rod i.e. longitudinal component and normal to rod i.e. the transverse component. The longitudinal component is taken into account by considering about one third portion of the connecting rod on the small end side as reciprocating and remaining two third as rotating with the crank.

Due to transverse component, a centrifugal force will act on every part of the rod the bending force will be zero at the piston pin and maximum at the crank pin. The variation can be assumed to be triangular.

If C is centripetal force acting on a unit length at the crank pin. The C is maximum when the crank and connecting rod are at right angles.

$$\text{Max. Value of } C = \rho A w^2 r \quad (10.3)$$

P = Density of material

A = cross section area of rod

w = angular speed

r = crank radius

Max. Bending moment occurs at a distance of $l/\sqrt{3}$, so maximum bending moment is given by

$$M_{\max} = 0.128 F_n l, \text{ where } F_n = Cl/2$$

$$\text{Maximum bending stress} = M_{\max}/Z \quad (10.4)$$

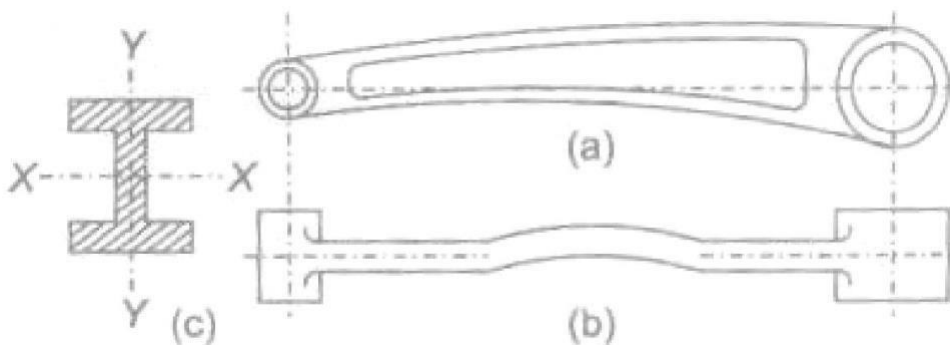

Figure 10.2 Buckling of Connecting Rod

$$\text{Buckling load} = f_{cu}A/(1 + a(l/k)^2), N \quad (10.5)$$

f_{cu} = ultimate crushing stress ,

A = section area

l = equivalent length

k = radius of gyration about axis of buckling, m

$$\text{Buckling load} = \text{Max. gas load} \times \text{FOS} = (\pi D^2 p_{\max} X \text{fos}) / 4 \quad (10.6)$$

7. Sample problem:

Q.1 Design a connecting rod for an I.C. engine running at 1800 r.p.m. and developing a maximum pressure of 3.15 N/mm². The diameter of the piston is 100 mm ; mass of the reciprocating parts per cylinder 2.25 kg; length of connecting rod 380 mm; stroke of piston 190 mm and compression ratio 6 : 1. Take a factor of safety of 6 for the design. Take length to diameter ratio for big end bearing as 1.3 and small end bearing as 2 and the corresponding bearing pressures as 10 N/mm² and 15 N/mm². The density of material of the rod may be taken as 8000 kg/m³ and the allowable stress in the bolts as 60 N/mm² and in cap as 80 N/mm². The rod is to be of I-section for which you can choose your own proportions. Draw a neat dimensioned sketch showing provision for lubrication. Use Rankine formula for which the numerator constant may be taken as 320 N/mm² and the denominator constant 1 / 7500.